



Town of Belmont

Belmont Middle and High School Building Committee

William Lovallo, Chair
John Phelan
David Blazon
Kate Bowen
Chris Messer, Secretary
Amy Zuccarello

Michael McAllister, Treasurer
Patricia Brusch, Vice Chair
Thomas Caputo
Jamie Shea
Joseph DeStefano

Patrice Garvin
Diane Miller
Joel Mooney
Robert McLaughlin
Emma Thurston

Date: November 29, 2023

To: Planning Board

Subject: Amend Order of Conditions to Remove Dugout Shelters at Baseball and Softball Fields

The Belmont Middle and High School Building Committee [Building Committee] is requesting temporary relief and an amendment to the Order of Conditions to remove dugout shelters at the baseball and softball fields as a condition to close out the open permit.

The Building Committee had plans in place to have the shelters installed this past summer. The Brendan Grant Foundation, following review of the shelter design, informed the Committee this past spring that they intended to install a different type of shelter to resemble the former baseball dugout shelters which were demolished in 2020. The Brendan Grant Foundation and Building Committee decided that it was not good use of taxpayer dollars to have new shelters removed so the Building Committee eliminated the shelters approved by the Planning Board from the project. We approached the Planning Board this past June to discuss the alternate solution proposed by the Brendan Grant Foundation. Following further considerations of a new dugout shelter design, the Brendan Grant Foundation informed the Building Committee this past summer that they intended to use the shelters approved by the Planning Board and enhance them with a future project construction effort independent of the Belmont Middle and High School project. Unfortunately, the original shelters purchased in 2020 were canceled, so the Building Committee had to requote and approve a new order of shelters this fall, thus delaying the installation of the shelters until next spring.

The Building Committee is now committed to installing the shelters as presented to the Planning Board during the Site Plan Review meetings in 2019 and 2020. Evidence of that commitment is attached herein in documentation with Sportsfield Specialties Inc., the canopy vendor, that includes the signed cost estimate, submitted shop drawings, and the purchase order from the Town of Belmont. The expected schedule for delivery of these canopies is early spring and they will be installed immediately upon delivery in time for spring sports. Evidence of the delivery time frame from Sportsfield Specialties Inc. is attached herein.

It is the desire of the Building Committee that the Planning Board approve this request so that we can close out the project permit this year and begin the State audit effort which must be completed before we receive the final State grant payment. If the Planning Board grants this request, we will be able to accelerate this State audit by at least four months.

The Committee appreciates the Planning Board's consideration in this matter.

Sincerely,



Bill Lovallo
Chair, Belmont Middle and High School Building Committee



Remit To:
Sportsfield Specialties
PO Box 231
Delhi, NY 13753

Billing Questions:
Phone: 607.746.8911
Email: billing@sportsfield.com

Quote Number: 88703

QUOTE

Page: 1 of 2

Quote To: Estimator US	Ship To: Brendan Grant Memorial Field Belmont High School Belmont, MA 02478	Date: 10/10/2023 Expires: 12/9/2023 PO Num: Belmont High School Middle School Building Committee Sales Person: Dan DeVantier Cell: 607-437-7301 Email: ddevantier@sportsfield.com
---	--	---

Contract #KPN202001-02

USD

Line	Part	Description	Qty /	Sales UoM	Unit Price	Ext. Price
6	GD8X32	GameShade® Modular Baseball/Softball Dugout - 8'W x 32'L, Includes Standard Roofing and Powder Coat Finish Options and Base Plate Mounting Hardware, Professionally Pre-Engineered to Meet ASCE 7-10 Wind Rating Up To 140 MPH Exposure C and 60 PSF Ground Snow Load Requirements	2.00	EA	\$14,060.00	\$28,120.00
7	GD-CUSTOM	Custom GameShade® Dugout Product GameShade® Modular Baseball/Softball Dugout - 8'W x 28'L, Includes Standard Roofing and Powder Coat Finish Options and Base Plate Mounting Hardware, Professionally Pre-Engineered to Meet ASCE 7-10 Wind Rating Up To 140 MPH Exposure C and 60 PSF Ground Snow Load Requirements	2.00	EA	\$14,060.00	\$28,120.00

QUOTE - Miscellaneous Charge -	
Description	Ext. Price
1.) Freight-NY2-Direct	\$2,978.00

Current dugout lead times approximately four months from time of color selection, submittal approval, and deposit payment to confirm order placement.

Exact delivery timeframe to be confirmed approximately 1-2 weeks prior to delivery.

Lines Total	\$56,240.00
Total Taxes	\$0.00
Line Miscellaneous	\$0.00
Quote Miscellaneous	\$2,978.00
Quote Total	\$59,218.00



Remit To:
Sportsfield Specialties
PO Box 231
Delhi, NY 13753

Billing Questions:
Phone: 607.746.8911
Email: billing@sportsfield.com

Quote Number: 88703

QUOTE

Page: 2 of 2

General Terms, unless other project-specific notes specified:

1. Customer is responsible for material take-off, quantities and specification compliance and/or equivalency of quoted products.
2. All prices listed are in US Dollars
3. Delivery is 2-8 Weeks after receipt of purchase order, credit approval, and acceptance of color, material(s) and design.
4. All freight is FOB Origin. **Freight rates are estimates provided at the time of quotation. Actual freight rates, include shipping & handling, will be billed at the time of shipment. The customer is responsible for any difference between the quoted freight rate and the actual freight rate at the time of shipment.** The actual freight rates may differ from the estimates as a result of variable factors, such as the change in product quantity and/or material order, state of national economy, fuel costs, capacity and/or rate levels at the time of shipment. Split orders will require additional freight charges. Freight quoted does not include additional equipment to unload or unloading services, assembly or installation.
5. Applicable State and Local Sales Tax will be added to the final invoice unless a tax exempt or Resale Certificate is provided prior to order shipment.
6. Wire transfers, by check and established credit terms are accepted payment methods. Accepted credit cards are VISA, Mastercard and American Express.
7. Pricing assumes any electrical connections and wiring are supplied by others unless otherwise indicated.
8. Customer is responsible for approval and associated cost of any applicable local and state codes.
9. Due to the increase of steel and aluminum raw material pricing caused by increased demand, coupled with market instability and uncertainty due to the implementation of international trade tariffs, Sportsfield Specialties, Inc. will no longer be able to guarantee current product pricing after this quotation has expired in sixty (60) days. To avoid a potential product price increase, customers will need to provide Sportsfield Specialties, Inc. with a fully executed purchase order or letter of intent before this quotation expires to guarantee this product pricing. Sportsfield Specialties, Inc reserves the right to requote product pricing as necessary based on current steel and aluminum raw material pricing once this quotation has expired in sixty (60) days.

Date

October 20, 2023

Signature

Printed Name/Title

William D. Lovallo, Chair, Belmont Middle and High School Building Committee

Large Item Shipping

Please be aware that due to our limited storage capacity, we do not have much flexibility to extend ship dates for certain products. Please let us know Immediately If you need to adjust your shipment date.

RAW Material Volatility

DISCLAIMER: Due to the ongoing Increase of steel and aluminum raw material pricing caused by Increased demand, coupled with market instability and uncertainty due to the Implementation of International trade tariffs, Sportsfield Specialties, Inc. will no longer be able to guarantee current product pricing after this quotation has expired In sixty (60) days. To avoid a potential product price Increase, customers will need to provide Sportsfield Specialties, Inc. with a fully executed purchase order or letter of Intent before this quotation expires to guarantee this product pricing. Sportsfield Specialties, Inc. reserves the right to requote product pricing as necessary based on current steel and aluminum raw material pricing once this quotation has expired In sixty (60) days.

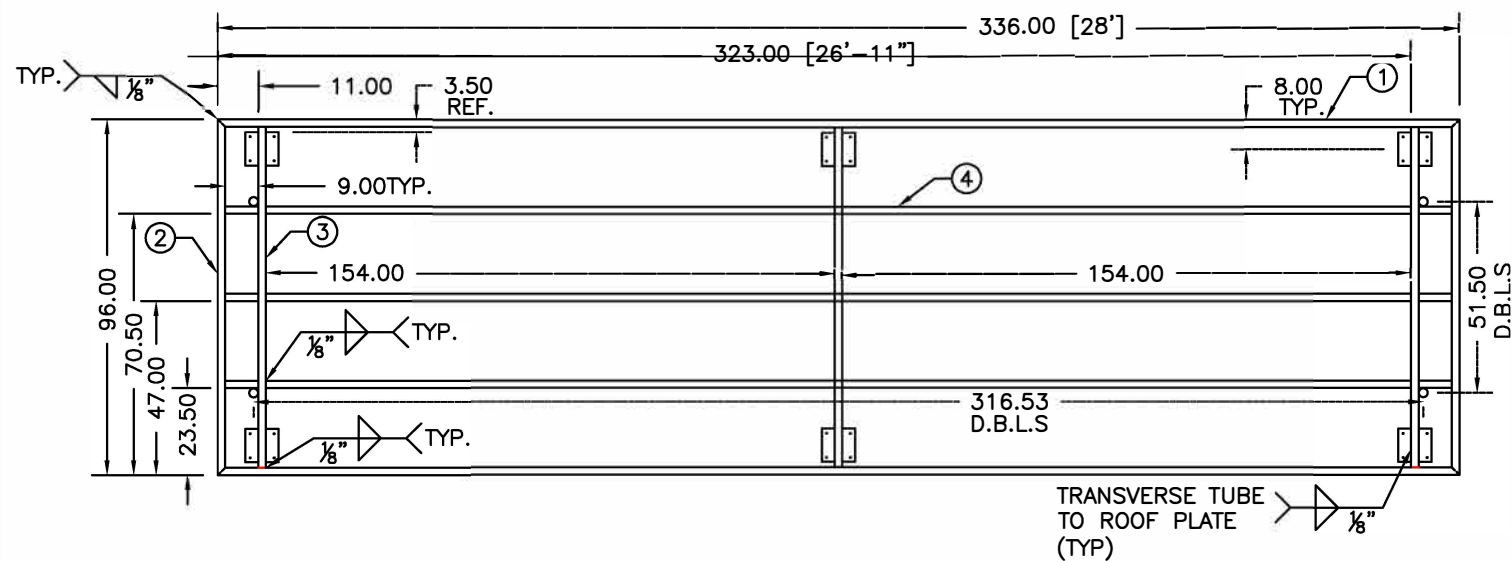

1 PLAN VIEW
S1

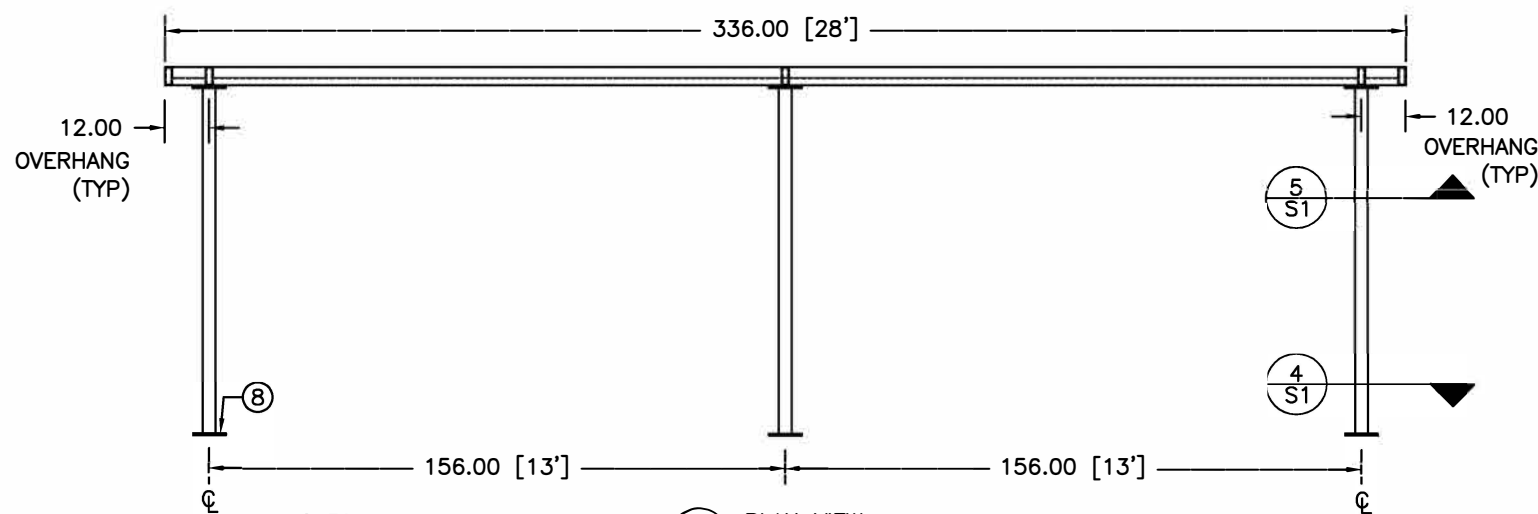

2 PLAN VIEW
S1

NOTES:

1. THE 29 GA ROOF DECKING IS NOT SHOWN FOR CLARITY.
2. COLUMNS ARE TO BE CENTERED ON THE BASE AND CAP PLATES.
3. USE (4) $\phi 5/8$ " A307 BOLTS TO BOLT THE COLUMN CAP PLATES TO THE ROOF PLATES.
4. SEE FOUNDATION DRAWINGS FOR ANCHORAGE REQUIREMENTS.
5. THE LIFTING EYE BOLT SLEEVES SHALL BE WELDED SUCH THAT THE TOP IS 1" ABOVE THE TOP OF THE ROOF FRAME IN ORDER TO CLEAR THE 3/4" METAL ROOF SHEET'S HIGH RIB.
6. BEFORE WELDING THE SLEEVES INTO PLACE, THE EYE BOLTS MUST BE THREADED INTO THE SLEEVES TO ACHIEVE THE ORIENTATION SHOWN IN DETAIL "6".
7. Fully Welded frame

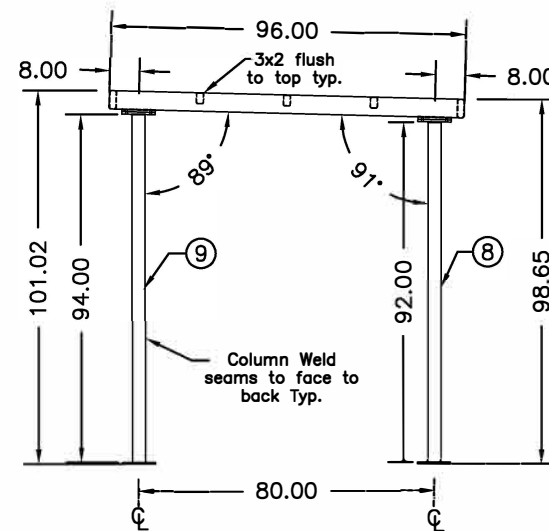

3 SIDE ELEVATION
S1

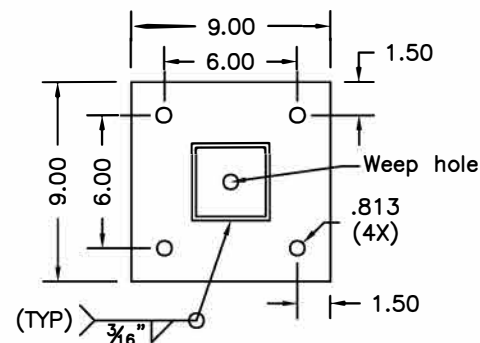

4 COLUMN BASE PLATE
S1

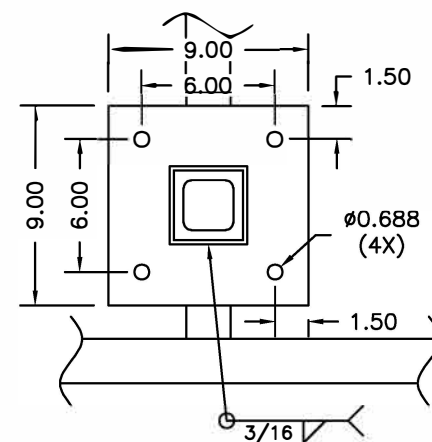

5 COLUMN CAP PLATE
S1

ITEM NO.	DESCRIPTION	COMMENTS
1	HSS 5x2x3/16	LONGITUDINAL ROOF PERIMETER TUBE
2	HSS 5x2x3/16	TRANSVERSE ROOF PERIMETER TUBE
3	HSS 5x2x3/16	TRANSVERSE ROOF TUBE
4	HSS 3x2x11 ga.	LONGITUDINAL ROOF TUBE
5	HSS 3x2x11 ga.	LONGITUDINAL ROOF TUBE
7	9x9x5/8 A36 PLATE	ROOF PLATES
8	HSS 3-1/2x3-1/2x3/16	REAR COLUMN ASSEMBLY
9	HSS 3-1/2x3-1/2x3/16	FRONT COLUMN ASSEMBLY
10	2.5" TAPPED STEEL ROUNDSTOCK	LIFTING EYEBOLT SLEEVE
11	11 ga. Steel	LIFTING SLEEVE END CAP

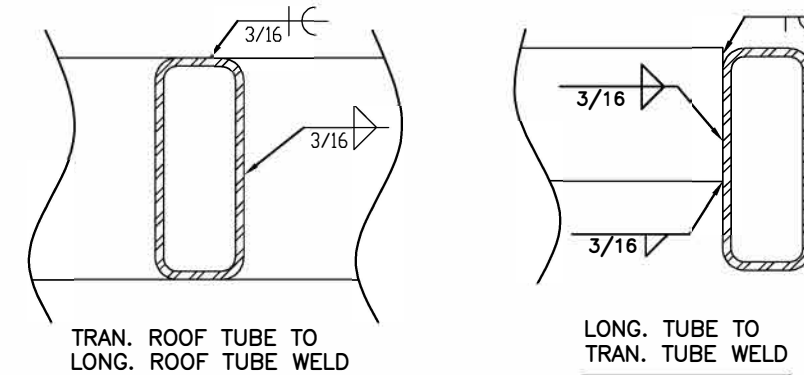

TRAN. ROOF TUBE TO LONG. ROOF TUBE WELD

LONG. TUBE TO TRAN. TUBE WELD

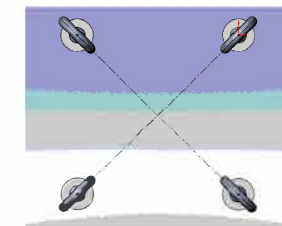

SEE NOTE #6

6 LIFTING EYE BOLT ORIENTATION
S1

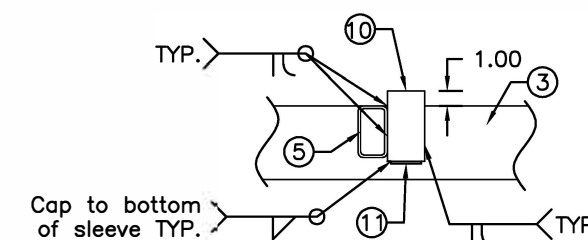

7 LIFTING EYE BOLT SLEEVE WELD DETAIL
S1

PROPRIETARY AND CONFIDENTIAL
THE INFORMATION CONTAINED IN THIS DRAWING IS THE SOLE PROPERTY OF SPORTSFIELD SPECIALTIES, INC. ANY REPRODUCTION IN PART OR AS A WHOLE WITHOUT THE WRITTEN PERMISSION OF SPORTSFIELD SPECIALTIES, INC. IS PROHIBITED.

NAME		DATE	SPORTSFIELD SPECIALTIES, INC.	
DRAWN	ND	10/30/23	GD-CUSTOM 8X28 SUBMITTAL	
CHECKED				
ENG APPR.				
MFG APPR.				
Q.A.				
COMMENTS:			Preliminary NOT FOR CONSTRUCTION	
SIZE	DWG. NO.		REV.	
B	S1			
SCALE: DNS	WEIGHT:		DATE: 10/30/23	

ITEM NO.	DESCRIPTION	COMMENTS
1	HSS 5x2x3/16	LONGITUDINAL ROOF PERIMETER TUBE
2	HSS 5x2x3/16	TRANSVERSE ROOF PERIMETER TUBE
3	HSS 5x2x3/16	TRANSVERSE ROOF TUBE
4	HSS 3x2x11 ga.	LONGITUDINAL ROOF TUBE
5	HSS 3x2x11 ga.	LONGITUDINAL ROOF TUBE
7	9x9x5/8 A36 PLATE	ROOF PLATES
8	HSS 3-1/2x3-1/2x3/16	REAR COLUMN ASSEMBLY
9	HSS 3-1/2x3-1/2x3/16	FRONT COLUMN ASSEMBLY
10	2.5" TAPPED STEEL ROUNDSTOCK	LIFTING EYEBOLT SLEEVE
11	11 ga. Steel	LIFTING SLEEVE END CAP

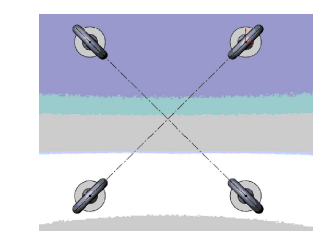
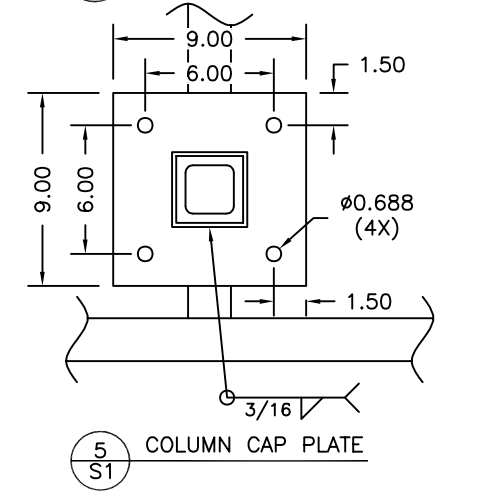
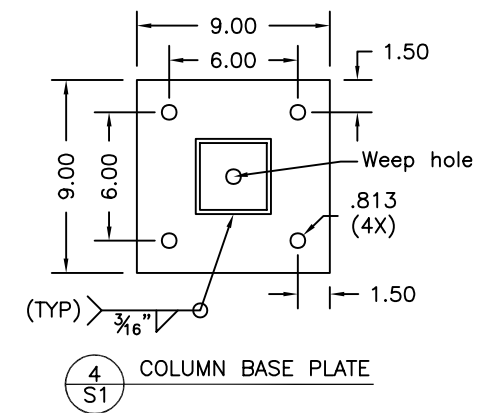
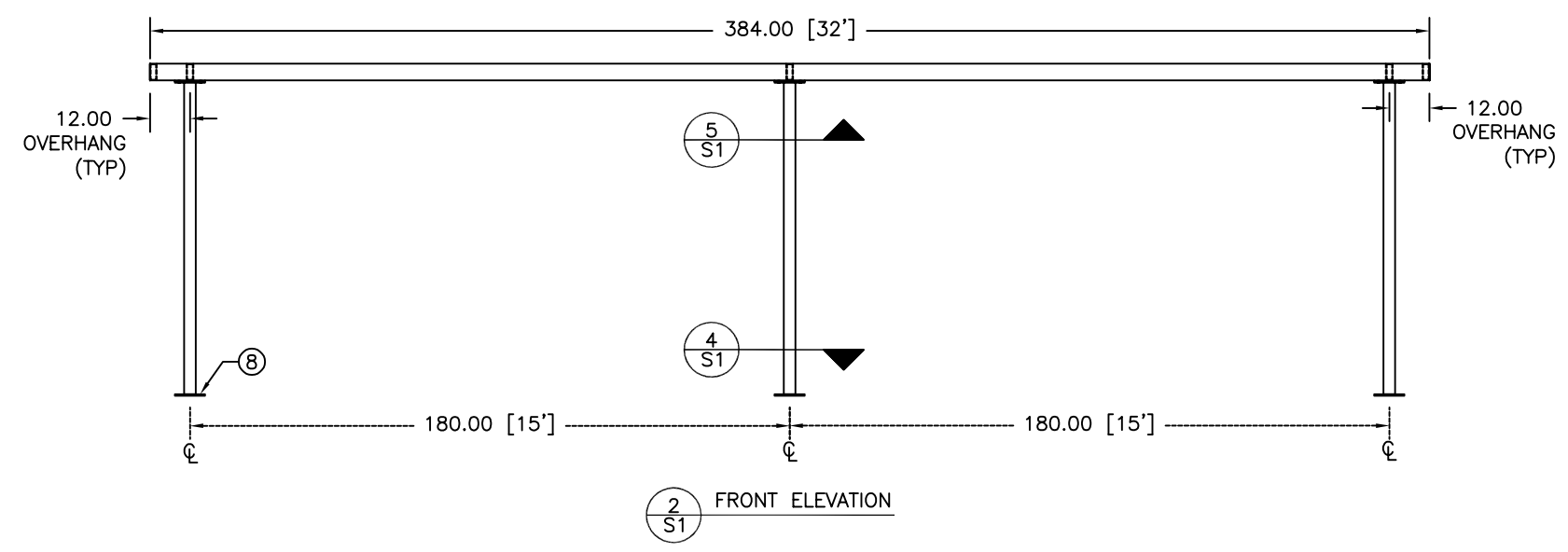
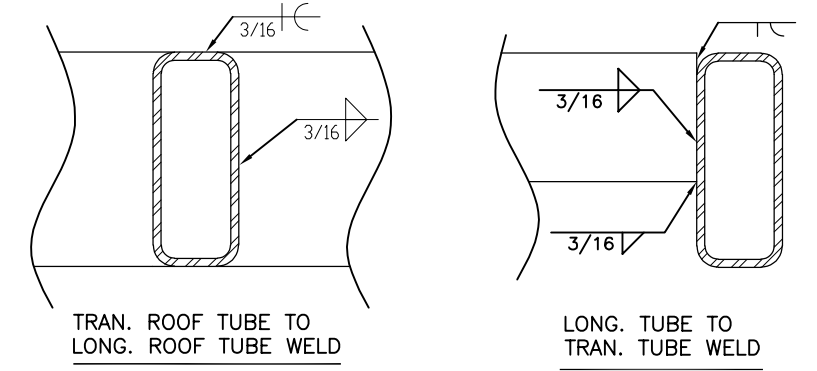
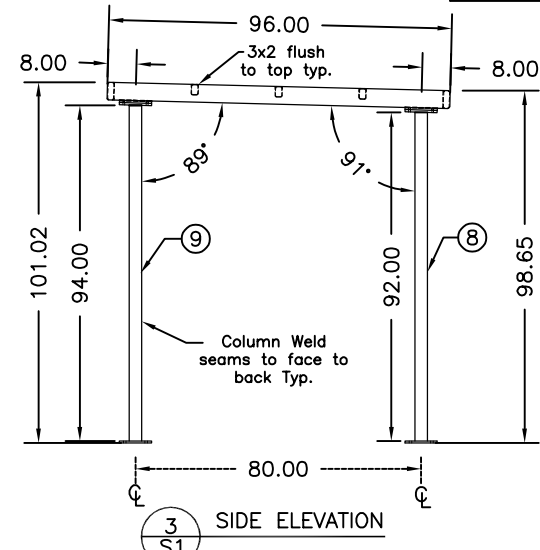
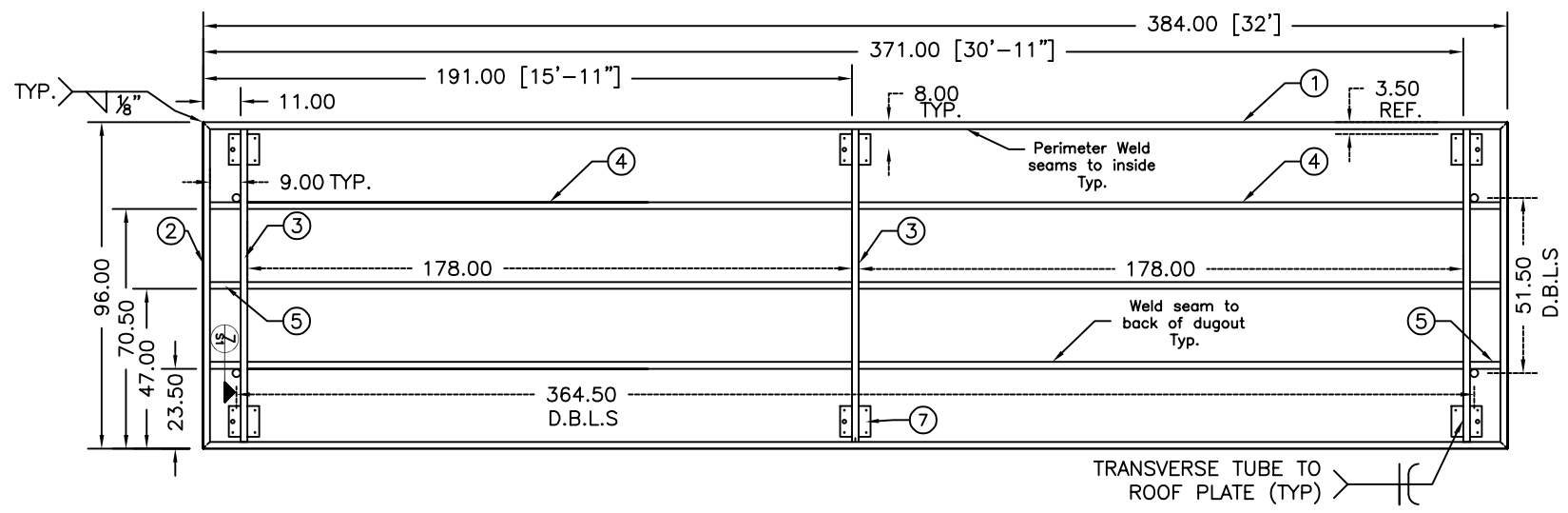

6 LIFTING EYE BOLT ORIENTATION

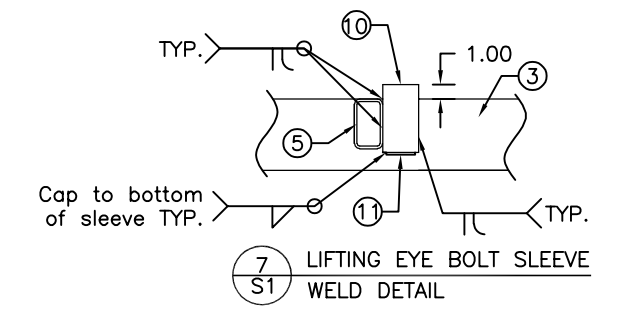

- NOTES:
1. THE 29 GA ROOF DECKING IS NOT SHOWN FOR CLARITY.
 2. COLUMNS ARE TO BE CENTERED ON THE BASE AND CAP PLATES.
 3. USE (4) $\phi 5/8"$ A307 BOLTS TO BOLT THE COLUMN CAP PLATES TO THE ROOF PLATES.
 4. SEE FOUNDATION DRAWINGS FOR ANCHORAGE REQUIREMENTS.
 5. THE LIFTING EYE BOLT SLEEVES SHALL BE WELDED SUCH THAT THE TOP IS 1" ABOVE THE TOP OF THE ROOF FRAME IN ORDER TO CLEAR THE $3/4"$ METAL ROOF SHEET'S HIGH RIB.
 6. BEFORE WELDING THE SLEEVES INTO PLACE, THE EYE BOLTS MUST BE THREADED INTO THE SLEEVES TO ACHIEVE THE ORIENTATION SHOWN IN DETAIL "6".
 7. Fully Welded frame

PROPRIETARY AND CONFIDENTIAL
THE INFORMATION CONTAINED IN THIS DRAWING IS THE SOLE PROPERTY OF SPORTSFIELD SPECIALTIES, INC. ANY REPRODUCTION IN PART OR AS A WHOLE WITHOUT THE WRITTEN PERMISSION OF SPORTSFIELD SPECIALTIES, INC. IS PROHIBITED.

NAME		DATE	SPORTSFIELD SPECIALTIES, INC.	
DRAWN	ND	10/30/23	GD8X32 SUBMITTAL	
CHECKED				
ENG APPR.				
MFG APPR.				
COMMENTS:			S1	
Preliminary NOT FOR CONSTRUCTION				
SIZE	DWG. NO.	REV.	DATE: 10/30/23	
B				
SCALE: DNS	WEIGHT:			



Town of Belmont

P.O. Box 56
Belmont, MA 02478-0900
PHONE: (617) 993-2620

Purchase Order

Fiscal Year 2024

Page: 1 of 1

THIS NUMBER MUST APPEAR ON ALL INVOICES, PACKAGES AND SHIPPING PAPERS.

Bill To

Town Administrator's Office
Town of Belmont
P O Box 56
Belmont, MA 02478
Phone: 617-993-2610

Purchase Order # **2400317**

Delivery must be made within doors of specified destination.

Vendor

SPORTSFIELD SPECIALTIES INC
41155 STATE HIGHWAY 10
PO BOX 231
DELHI, NY 13753

Ship To

Town Administrator's Office
Town of Belmont Town Hall
455 Concord Ave
Belmont, MA 02478
Phone: 617-996-2610

VENDOR PHONE NUMBER	VENDOR FAX NUMBER	REQUISITION NUMBER	DELIVERY REFERENCE
		30360	

DATE ORDERED	VENDOR NUMBER	DEPARTMENT/LOCATION
11/15/2023	13292	Town Administration

NOTES

ITEM #	DESCRIPTION / PART #	QTY	UOM	UNIT PRICE	EXTENDED PRICE
1	BMHSBC - Dugouts - SPORTSFIELD SPECIALTIES INC	1.0	EACH	\$59,218.00	\$59,218.00

CONDITIONS

- Each box or package shall contain a memorandum showing contents and shipping name and address.
- No Charge shall be made by the seller for boxing, packaging, or cartage unless by agreement.
- Any charges assessed through seller's failure to consign shipment on this order exactly in accordance with shipping and directions given herein will be charged to the seller.
- In accepting this order, the seller certifies that the merchandise furnished will be produced and sold in conformity with applicable laws.
- In accepting this order, the seller agrees to indemnify the buyer against all loss resulting from any claim of patent infringement arising out of the purchase of goods under this order.
- All materials shall be received subject to buyer's exam, inspection, approval or rejection within a reasonable time.
- The buyer reserves the right to cancel any part of this order if shipment is not made according to the terms herein.
- In order to be considered for prompt payment, invoices with a P.O. number must be received in the accounting office no later than the 20th day of the calendar month following date of delivery to the town.
- In as much as the Town of Belmont, MA is exempt from Sales Tax and Excise Tax, such taxes are not to be included in invoice amounts. Complete Certificates for Excise Taxes will be furnished upon request by the seller.

INVOICE IN DUPLICATE

Your acceptance of this order constitutes an agreement to supply the material ordered at the prices and on the terms and conditions set forth at left.

IMPORTANT: Read Terms and Conditions provided as part of this purchase order.

Chief Procurement Officer

Vendor Copy

Purchase Order Total \$59,218.00

Bill Lovallo

From: White, Donald <DWhite@chasolutions.com>
Sent: Tuesday, November 28, 2023 1:39 PM
To: Bill Lovallo
Cc: Gatzunis, Tom; DelGreco, Tony; Ferdenzi, Justin; Zelikman, Jacob; Saccone, Sandra
Subject: FW: [--EXTBelmont MA New High School - Dugout Order to Baseball and Softball

Bill – see EM below from Sports Field. They can not give a definitive date yet, but said they can once we get closer. However, they are stating they are expecting shipment in early March, 2024 for the four dugouts.

Don White

Donald White
Sr. Project Manager

CHA
Mobile: (617) 293-4954
Office: (617) 865-6155

dwhite@chasolutions.com
www.chasolutions.com



Please note my email address has changed

Finding a better way.

From: Lauren Iwanow <lauren.iwanow@sportsfield.com>
Sent: Tuesday, November 28, 2023 10:00 AM
To: White, Donald <DWhite@chasolutions.com>; Dan DeVantier <dan.devantier@sportsfield.com>
Cc: Gatzunis, Tom <TGatzunis@chasolutions.com>; DelGreco, Tony <TDelGreco@chasolutions.com>; Zelikman, Jacob <JZelikman@chasolutions.com>
Subject: RE: [--EXTERNAL--]: RE: [External Email] - Belmont MA New High School - Dugout Order to Baseball and Softball

Don, we won't have a final date until we get closer. The expectation right now is shipment in early March 2024.

Thanks,

Lauren Iwanow, Northeast/Mid-Atlantic/Midwest Senior Inside Sales

Sportsfield Specialties, Inc.
Direct Sales Division
Direct: 607.746.1454 Mobile: 607-267-6311
lauren.iwanow@sportsfield.com
41155 State Hwy 10 Delhi, NY 13753
www.sportsfield.com

